

14 August 2006

AGREEMENT

CONCERNING THE ADOPTION OF UNIFORM TECHNICAL PRESCRIPTIONS FOR WHEELED VEHICLES, EQUIPMENT AND PARTS WHICH CAN BE FITTED AND/OR BE USED ON WHEELED VEHICLES AND THE CONDITIONS FOR RECIPROCAL RECOGNITION OF APPROVALS GRANTED ON THE BASIS OF THESE PRESCRIPTIONS */

(Revision 2, including the amendments which entered into force on 16 October 1995)

Addendum 6: Regulation No. 7

Revision 4

Incorporating all valid text up to:

Supplement 6 to the 02 series of amendments - Date of entry into force: 26 August 2002 **/

Supplement 7 to the 02 series of amendments - Date of entry into force: 16 July 2003

Supplement 8 to the 02 series of amendments - Date of entry into force: 26 February 2004

Corrigendum 1 to Supplement 8 to the 02 series of amendments, subject of Depository
Notification C.N.159.2004.200.TREATIES-1 dated 4 March 2004

Supplement 9 to the 02 series of amendments - Date of entry into force: 9 November 2005

Supplement 10 to the 02 series of amendments - Date of entry into force: 4 July 2006

UNIFORM PROVISIONS CONCERNING THE APPROVAL OF FRONT AND REAR POSITION (SIDE) LAMPS, STOP-LAMPS AND END-OUTLINE MARKER LAMPS FOR MOTOR VEHICLES (EXCEPT MOTOR CYCLES) AND THEIR TRAILERS



UNITED NATIONS

*/ Former title of the Agreement:

Agreement Concerning the Adoption of Uniform Conditions of Approval and Reciprocal Recognition of Approval for Motor Vehicle Equipment and Parts, done at Geneva on 20 March 1958.

**/ For Ukraine, the date of entry into force is 26 October 2002.

Regulation No. 7

UNIFORM PROVISIONS CONCERNING THE APPROVAL OF FRONT AND REAR
POSITION (SIDE) LAMPS, STOP-LAMPS AND END-OUTLINE MARKER LAMPS FOR
MOTOR VEHICLES (EXCEPT MOTOR CYCLES) AND THEIR TRAILERS

CONTENTS

REGULATION	<u>Page</u>
1. Definitions	5
2. Application for approval	5
3. Markings.....	7
4. Approval	8
5. General specifications	12
6. Intensity of light emitted	13
7. Test procedure	17
8. Colour of light emitted	18
9. Conformity of production	18
10. Penalties for non-conformity of production	19
11. Production definitely discontinued	19
12. Remarks concerning colours and particular devices	19
13. Names and addresses of Technical Services responsible for conducting approval tests, and of Administrative Departments	19
14. Transitional provisions	20

CONTENTS (continued)

ANNEXES

- Annex 1 - Front and rear position (side) lamps, end-outline marker lamps and stop lamps: minimum angles required for light distribution in space of these lamps
- Annex 2 - Communication concerning the approval or extension or refusal or withdrawal of approval or production definitely discontinued of a type of device pursuant to Regulation No. 7
- Annex 3 - Examples of arrangements of the approval marks
- Annex 4 - Photometric measurements
- Annex 5 - Colours of lights
- Annex 6 - Minimum requirements for conformity of production control procedures
- Annex 7 - Minimum requirements for sampling by an inspector

1. DEFINITIONS

For the purpose of this Regulation,

- 1.1. "Front position (side) lamp" means the lamp used to indicate the presence and the width of the vehicle when viewed from the front;
- 1.2. "Rear position (side) lamp" means the lamp used to indicate the presence and the width of the vehicle when viewed from the rear;
- 1.3. "Stop-lamp" means the lamp used to indicate to other road-users to the rear of the vehicle that its driver is applying the service brake. The stop-lamps may be activated by the application of a retarder or a similar device;
- 1.4. "End-outline marker lamp" means a lamp fitted near to the extreme outer edges and as close as possible to the top of the vehicle and intended to indicate clearly the vehicle's overall width. In the case of certain power-driven vehicles and trailers, this lamp is intended to complement the vehicle's position (side) lamps and draw special attention to its outline;
- 1.5. Definitions of terms:
- The definitions given in Regulation No. 48 and its series of amendments in force at the time of application for type-approval shall apply to this Regulation.
- 1.6. "Front and rear position lamps, stop-lamps and end-outline marker lamps of different type" means lamps which differ in each said category in such essential respects as:
- (a) the trade name or mark;
 - (b) the characteristics of the optical system, (levels of intensity, light distribution angles, category of filament lamp, light source module, etc.);
 - (c) the system used to reduce illumination at night - in the case of stop-lamps with two levels of intensity.

A change of the colour of the filament lamp or the colour of any filter does not constitute a change of type.

2. APPLICATION FOR APPROVAL

- 2.1. The application for approval shall be submitted by the holder of the trade name or mark or by his duly accredited representative. It shall specify:

- 2.1.1. The purpose or purposes for which the device submitted for approval is intended and whether it may also be used in an assembly of two lamps of the same kind/type;
- 2.1.2. In the case of an end-outline marker lamp, whether it is intended to emit white or red light;
- 2.1.3. In the case of a category S3 stop lamp, whether it is intended to be mounted outside or inside (behind the rear window) the vehicle;
- 2.1.4. At the choice of the applicant, that the device may be installed on the vehicle with different inclinations of the reference axis in respect to the vehicle reference planes and to the ground or rotate around its reference axis; these different conditions of installation shall be indicated in the communication form.
- 2.2. For each type of device, the application shall be accompanied by:
- 2.2.1. Drawings, in triplicate, in sufficient detail to permit identification of the type of the device and showing in what geometrical position(s) the device (and if applicable for category S3 lamps the rear window) may be mounted on the vehicle; the axis of observation to be taken is the axis of reference in the tests (horizontal angle $H = 0^\circ$, vertical angle $V = 0^\circ$); and the point to be taken as the centre of reference in the said tests. The drawings shall show the position intended for the approval number and the additional symbols in relation to the circle of the approval mark;
- 2.2.2. A brief technical description stating, in particular, with the exception of lamps with non-replaceable light sources:
- (a) the category or categories of filament lamp(s) prescribed; this filament lamp category shall be one of those contained in Regulation No. 37; and/or
 - (b) the light source module specific identification code.
- In the case of a category S3 stop lamp, which is intended to be mounted inside the vehicle, the technical description shall contain the specification of the optical properties (transmission, colour, inclination, etc.) of the rear window(s).
- 2.2.3. In the case of a stop-lamp with two levels of intensity, an arrangement diagram and a specification of the characteristics of the system ensuring the two levels of intensity;
- 2.2.4. Two samples; if the approval is applied for devices which are not identical but are symmetrical and suitable for mounting one on the left and one on the right side of the vehicle, the two samples submitted may be identical and be suitable for

mounting only on the right or only on the left side of the vehicle; in the case of a stop-lamp with two levels of intensity, the application shall also be accompanied by two samples of the parts constituting the system which ensures two levels of intensity.

2.2.5. In the case of a category S3 stop lamp, which is intended to be mounted inside the vehicle, a sample plate or sample plates (in case of different possibilities) having the equivalent optical properties corresponding to those of the actual rear window(s).

3. MARKINGS

Devices submitted for approval:

3.1. Must bear the trade name or mark of the applicant; this marking must be clearly legible and be indelible;

3.2. With the exception of lamps with non-replaceable light sources it must bear a clearly legible and indelible marking indicating:

(a) the category or categories of filament lamp(s) prescribed; and/or

(b) the light source module specific identification code

3.3. Must comprise a space of sufficient size for the approval marking and the additional symbols prescribed in paragraph 4.2. below; this space shall be shown in the drawings mentioned in paragraph 2.2.1. above;

3.4. In the case of lamps with non-replaceable light sources or light source module(s), the lamp shall bear the marking of the rated voltage or the range of voltage and the rated wattage.

3.5. Lamps operating at voltages other than the nominal rated voltages of 6 V, 12 V or 24 V respectively, by the application of an additional supply system or having a secondary operating mode, must bear a marking denoting the rated secondary design voltage, if the additional supply is not part of the device.

3.6. In the case of lamps with light source module(s), the light source module(s) shall bear:

3.6.1. the trade name or mark of the applicant; this marking must be clearly legible and indelible;

3.6.2. the specific identification code of the module; this marking must be clearly legible and indelible.

This specific identification code shall comprise the starting letters "MD" for "MODULE" followed by the approval marking without the circle as prescribed in paragraph 4.2.1.1. below; this specific identification code shall be shown in the drawings mentioned in paragraph 2.2.1. above.

The approval marking does not have to be the same as the one on the lamp in which the module is used, but both markings shall be from the same applicant.

3.6.3. The marking of the rated voltage and rated wattage.

4. APPROVAL

4.1. General

4.1.1. If the two devices which are submitted in pursuance of paragraph 2.2.4. above satisfy the provisions of this Regulation, approval shall be granted.

4.1.2. When two or more lamps are part of the same unit of grouped, combined or reciprocally incorporated lamps, approval may be granted only if each of these lamps satisfies the provisions set out in this Regulation or in another Regulation. Lamps not satisfying the provisions of any of those Regulations shall not be part of such unit of grouped, combined or reciprocally incorporated lamps. This provision shall not apply to headlamps fitted with a double-filament bulb, where only one beam is approved.

4.1.3. An approval number shall be assigned to each type approved. Its first two digits (at present 02) shall indicate the series of amendments incorporating the most recent major technical amendments made to the Regulation at the time of issue of the approval. The same Contracting Party shall not assign the same number to another type of device covered by this Regulation, except in case approval is extended to a device which only differs from the already approved device by the colour of the light emitted.

4.1.4. Notice of approval or of extension or refusal or of withdrawal of approval or production definitely discontinued of a type of device pursuant to this Regulation shall be communicated to the Parties to the 1958 Agreement applying this Regulation, by means of a form conforming to the model in Annex 2 to this Regulation.

4.1.5. Every device conforming to a type approved under this Regulation shall bear, in the space referred to in paragraph 3.3. above, and in addition to the markings prescribed in paragraphs 3.1. and 3.2. or 3.4. respectively, an approval mark as described in paragraphs 4.2. and 4.3. below.

4.2. Composition of the approval mark

The approval mark shall consist of:

4.2.1. An international approval mark, comprising:

4.2.1.1. A circle surrounding the letter "E" followed by the distinguishing number of the country which has granted approval; 1/

4.2.1.2. The approval number prescribed in paragraph 4.1.3. above.

4.2.2. The following additional symbol or symbols:

4.2.2.1. On devices meeting the requirements of this Regulation in respect of the front position (side) lamps, the letter "A";

4.2.2.2. On devices meeting the requirements of this Regulation in respect of the rear position (side) lamps, the letter "R";

4.2.2.3. On devices meeting the requirements of this Regulation in respect of the stop-lamps, the letter "S" followed by the figure:

"1" when the device has one level of illumination;

"2" when the device has two levels of illumination;

"3" when the device meets the specific requirements for category S3 stop-lamps;

1/ for Germany, 2 for France, 3 for Italy, 4 for the Netherlands, 5 for Sweden, 6 for Belgium, 7 for Hungary, 8 for the Czech Republic, 9 for Spain, 10 for Serbia and Montenegro, 11 for the United Kingdom, 12 for Austria, 13 for Luxembourg, 14 for Switzerland, 15 (vacant), 16 for Norway, 17 for Finland, 18 for Denmark, 19 for Romania, 20 for Poland, 21 for Portugal, 22 for the Russian Federation, 23 for Greece, 24 for Ireland, 25 for Croatia, 26 for Slovenia, 27 for Slovakia, 28 for Belarus, 29 for Estonia, 30 (vacant), 31 for Bosnia and Herzegovina, 32 for Latvia, 33 (vacant), 34 for Bulgaria, 35 (vacant), 36 for Lithuania, 37 for Turkey, 38 (vacant), 39 for Azerbaijan, 40 for The former Yugoslav Republic of Macedonia, 41 (vacant), 42 for the European Community (Approvals are granted by its Member States using their respective ECE symbol), 43 for Japan, 44 (vacant), 45 for Australia, 46 for Ukraine, 47 for South Africa, 48 for New Zealand, 49 for Cyprus, 50 for Malta, 51 for the Republic of Korea, 52 for Malaysia and 53 for Thailand. Subsequent numbers shall be assigned to other countries in the chronological order in which they ratify or accede to the Agreement Concerning the Adoption of Uniform Technical Prescriptions for Wheeled Vehicles, Equipment and Parts which can be Fitted and/or be Used on Wheeled Vehicles and the Conditions for Reciprocal Recognition of Approvals Granted on the Basis of these Prescriptions, and the numbers thus assigned shall be communicated by the Secretary-General of the United Nations to the Contracting Parties to the Agreement.

- 4.2.2.4. On devices comprising both a rear position (side) lamp and a stop- lamp meeting the requirements of this Regulation in respect of such lamps, the letters "R" and "S1" or "S2" as the case may be, separated by a horizontal dash;
- 4.2.2.5. On front or rear position lamps of which the visibility angles are asymmetrical with regard to the reference axis in a horizontal direction, a horizontal arrow pointing towards the side on which the photometric specifications are met up to an angle of 80° H;
- 4.2.2.6. On devices which may be used as part of an assembly of two lamps, the additional letter "D" to the right of the symbol mentioned in paragraphs 4.2.2.1. and 4.2.2.4.;
- 4.2.2.7. On devices with reduced light distribution in conformity to paragraph 2.3. in Annex 4 to this Regulation a vertical arrow starting from a horizontal segment and directed downwards.
- 4.2.3. The two digits of the approval number (at present 02 corresponding to the 02 series of amendments which entered into force on 5 May 1991), which indicate the series of amendments incorporating the most recent major technical amendments made to the Regulation at the time of issue of the approval and, if necessary, the required arrow may be marked close to the above additional symbols.
- 4.2.4. The marks and symbols referred to in paragraphs 4.2.1. and 4.2.2. above shall be clearly legible and indelible even when the device is fitted in the vehicle.

4.3. Arrangement of the approval mark

4.3.1. Independent lamps

Annex 3, paragraphs 1 to 4, gives examples of the approval mark with the above-mentioned additional symbols.

If different types of lamps complying with the requirements of several Regulations uses the same outer lens having the same or different colour, a single international approval mark may be affixed, consisting of a circle surrounding the letter "E" followed by the distinguishing number of the country which has granted the approval, and an approval number. This approval mark may be located anywhere on the lamp, provided that:

- 4.3.1.1. It is visible after their installation.
- 4.3.1.2. The identification symbol for each lamp appropriate to each Regulation under which approval has been granted, together with the corresponding series of

amendments incorporating the most recent major technical amendments to the Regulation at the time of issue of the approval and if necessary, the required arrow shall be marked.

- 4.3.1.3. The size of the components of a single approval mark shall not be less than the minimum size required for the smallest of the individual marks under which approval has been granted.
- 4.3.1.4. The main body of the lamp shall include the space described in paragraph 3.3. above and shall bear the approval mark of the actual function(s).
- 4.3.1.5. Example 5 of Annex 3 to this Regulation gives examples of an approval mark with the above-mentioned additional symbols.
- 4.3.2. Grouped, combined or reciprocally incorporated lamps
 - 4.3.2.1. Where grouped, combined or reciprocally incorporated lamps have been found to comply with the requirements of several Regulations, a single international approval mark may be affixed, consisting of a circle surrounding the letter "E" followed by the distinguishing number of the country which has granted the approval, and an approval number. This approval mark may be located anywhere on the grouped, combined or reciprocally incorporated lamps, provided that:
 - 4.3.2.1.1. It is visible after their installation;
 - 4.3.2.1.2. No part of the grouped, combined or reciprocally incorporated lamps that transmits light can be removed without at the same time removing the approval mark.
 - 4.3.2.2. The identification symbol for each lamp appropriate to each Regulation under which approval has been granted, together with the corresponding series of amendments incorporating the most recent major technical amendments to the Regulation at the time of issue of the approval and, if necessary, the required arrow shall be marked:
 - 4.3.2.2.1. Either on the appropriate light-emitting surface,
 - 4.3.2.2.2. Or in a group, in such a way that each of the grouped, combined or reciprocally incorporated lamps may be clearly identified.
 - 4.3.2.3. The size of the components of a single approval mark shall not be less than the minimum size required for the smallest of the individual marks under which approval has been granted.

4.3.2.4. An approval number shall be assigned to each type approved. The same Contracting Party may not assign the same number to another type of grouped, combined or reciprocally incorporated lamps covered by this Regulation.

4.3.2.5. Paragraph 6 of Annex 3 to this Regulation gives examples of approval marks for grouped, combined or reciprocally incorporated lamps with all the above-mentioned additional symbols.

4.3.3. Lamps reciprocally incorporated with a type of headlamp of which the lens is also used for other types of headlamps

The provisions laid down in paragraph 4.3.2. above are applicable.

4.3.3.1. However, if different types of headlamps or of units of lamps including a headlamp comprise the same lens, the latter may bear the different approval marks relating to these types of headlamps or units or lamps, provided that the main body of the headlamp, even if it cannot be separated from the lens, also comprises the space described in paragraph 3.3. above and bears the approval marks of the actual functions. If different types of headlamps comprise the same main body, the latter may bear the different approval marks.

4.3.3.2. Paragraph 7 of Annex 3 to this Regulation gives examples of approval marks relating to lamps which are reciprocally incorporated with a headlamp.

4.3.4. The approval marking shall be clearly legible and indelible. It may be placed on an inner or outer part (transparent or not) of the device which cannot be separated from the transparent part of the device emitting the light. In any case the marking shall be visible when the device is fitted on the vehicle or when a movable part such as the hood or boot lid or a door is opened.

5. GENERAL SPECIFICATIONS

5.1. Each device supplied shall conform to the specifications set forth in paragraphs 6 and 8 below.

5.2. The devices must be so designed and constructed that in normal conditions of use, and notwithstanding the vibrations to which they may be subjected in such use, their satisfactory operation remains assured and they retain the characteristics prescribed by this Regulation.

5.3. Lamps having been approved as front or rear position (side) lamps, are deemed being also approved end-outline marker lamps.

5.4. Front and rear position (side) lamps which are grouped or combined or reciprocally incorporated may also be used as end-outline marker lamps.

- 5.5. Position (side) lamps, which are reciprocally incorporated with another function, using a common light source, and designed to operate permanently with an additional system to regulate the intensity of the light emitted, are permitted.
- 5.5.1. However, in the case of rear (side) position lamp reciprocally incorporated with a stop lamp, the device shall either:
- (a) be a part of a multiple light source arrangement, or
 - (b) be intended for use in a vehicle equipped with a failure monitoring system for that function.

In either case, a note shall be made within the communication document.

- 5.6. Light source module
- 5.6.1. The design of the light source module(s) shall be such that even in darkness the light source module(s) can be fitted in no other position, but the correct one.
- 5.6.2. The light source module(s) shall be tamperproof.
- 5.7. If the front position lamp incorporates one or more infrared radiation generators, the photometric and colour requirements for this front position lamp shall be met with and without the operation of the infrared radiation generator(s).

6. INTENSITY OF LIGHT EMITTED

- 6.1. In the reference axis, the light emitted by each of the two devices supplied must be of not less than the minimum intensity and of not more than the maximum intensity specified below:

<u>1/</u>	Minimum intensities cd	Maximum values in cd when used as		
		Single lamp	Lamp (single) marked "D" (para. 4.2.2.6.)	Total for the assembly of two or more lamps
6.1.1. Front position (side) lamps, front end-outline marker lamp	4	60 <u>2/</u>	42 <u>2/</u>	84 <u>2/</u>
6.1.2. Front position (side) lamps incorporated in headlamp	4	100 <u>2/</u>	-	-
6.1.3. Rear position (side) lamps, rear end-outline marker lamp	4	12 <u>2/</u>	8.5 <u>2/</u>	17 <u>2/</u>
6.1.4. Stop-lamps				
6.1.4.1. with 1 level of intensity (category S1)	60	185 <u>2/</u>	130 <u>2/</u>	260 <u>2/</u>
6.1.4.2. with 2 levels of intensity (category S2)				
6.1.4.2.1. by day	130	520 <u>2/</u>	366 <u>2/</u>	728 <u>2/</u>
6.1.4.2.2. by night	30	80 <u>2/</u>	56 <u>2/</u>	112 <u>2/</u>
6.1.4.3. Stop-lamps of category S3	25	80 <u>2/</u>	55 <u>2/</u>	110 <u>2/</u>

1/ The installation of the devices referred to above in power-driven vehicles and their trailers is provided for in the Regulations concerning the installation of lighting and light-signalling devices (Regulations Nos. 48 and 53).

2/ The total value of maximum intensity for an assembly of two or more lamps is given by multiplying by 1.4 the value prescribed for a single lamp.

When an assembly of two or more lamps having the same function is deemed to be, for the purpose of installation on a vehicle, a "single lamp" (following the definition of Regulation No. 48 and its series of amendments in force at the time of application for type approval), this

assembly shall comply with the minimum intensity required when one lamp has failed, and all the lamps together shall not exceed the admissible maximum intensity (last column of the table). In the case of a single lamp containing more than one light source:

- (a) all light sources which are connected in series are considered to be one light source;
- (b) the lamp shall comply with the minimum intensity required when any one light source has failed. However, for lamps designed for only two light sources, 50 per cent of the minimum intensity in the axis of reference of the lamp shall be considered sufficient, provided that a note in the communication form states that the lamp is only for use on a vehicle fitted with an operating tell-tale which indicates when any one of these two light sources has failed;
- (c) when all light sources are illuminated the maximum intensity specified for a single lamp may be exceeded provided that the single lamp is not marked "D" and the maximum intensity specified for an assembly of two or more lamps (last column of the table) is not exceeded.

- 6.2. Outside the reference axis and within the angular fields defined in the diagrams in Annex 1 to this Regulation, the intensity of the light emitted by each of the two devices supplied must:
- 6.2.1. In each direction corresponding to the points in the light distribution table reproduced in Annex 4 to this Regulation, be not less than the product of the minimum specified in paragraph 6.1. above by the percentage specified in the said table of the direction in question;
- 6.2.2. In no direction within the space from which the light-signalling device is visible, exceed the maximum specified in paragraph 6.1. above;
- 6.2.3. However, a luminous intensity of 60 cd shall be permitted for rear position (side) lamps reciprocally incorporated with stop-lamps (see paragraph 6.1.3. above) below a plane forming an angle of 5° with and downward from the horizontal plane;
- 6.2.4. Moreover,
- 6.2.4.1. Throughout the fields defined in the diagrams in Annex 1, the intensity of the light emitted must be not less than 0.05 cd for front and rear position (side) lamps and end-outline marker lamps, not less than 0.3 cd for stop-lamps with one level of intensity, and for stop-lamps with two levels of intensity 0.3 cd by day and 0.07 cd by night;
- 6.2.4.2. If a rear position (side) lamp is reciprocally incorporated with a stop-lamp, the ratio between the luminous intensities actually measured of the two lamps when turned on simultaneously at the intensity of the rear position (side) lamp when turned on alone should be at least 5 : 1 in the field delimited by the straight horizontal lines passing through $\pm 5^\circ$ V and the straight vertical lines passing through $\pm 10^\circ$ H of the light distribution table. If the stop-lamp has two levels of intensity, this requirement must be satisfied when the night condition is switched on;
- If the rear position (side) lamp or the stop lamp or both contain more than one light source and are considered as a single lamp as defined in note 2 of the table in paragraph 6.1. above, the values to be considered are those obtained with all sources in operation;
- 6.2.4.3. The provisions of paragraph 2.2. of Annex 4 to this Regulation on local variations of intensity must be observed.
- 6.3. The intensities shall be measured with the filament lamp(s) continuously alight and, in the case of devices emitting red light, in coloured light.

- 6.4. In the case of a stop-lamp providing two levels of intensity, the time that elapses between electrical supply being switched on and the light output measured on the reference axis to reach 90 per cent of the value measured in accordance with paragraph 6.3. above shall be measured for both the day and the night conditions of use. The time measured for the night condition of use shall not exceed that measured for the day condition of use.
- 6.5. Annex 4, to which reference is made in paragraph 6.2.1. above, gives particulars of the methods of measurement to be used.
7. TEST PROCEDURE
- 7.1. All measurements, photometric and colorimetric, shall be made with a colourless standard filament lamp of the category prescribed for the device, the supply voltage being so regulated as to produce the reference luminous flux required for that category of lamp.
- 7.1.1. In the case of a system with more than one intensity, the reference luminous flux prescribed for the specific category of filament lamp shall be applied to the greatest intensity.
- 7.1.2. All measurements, photometric and colorimetric, on lamps equipped with non-replaceable light sources (filament lamps and others) shall be made at 6.75 V, 13.5 V or 28.0 V, respectively.
- 7.1.3. In the case of light sources supplied by a special power supply, the above test voltages shall be applied to the input terminals of that power supply. The test laboratory may require from the manufacturer the special power supply needed to supply the light sources.
- 7.2. However, in the case of a stop-lamp for which an additional system is used to obtain the night-time intensity, the voltage applied to the system for measuring the night-time intensity shall be that which was applied to the filament lamp for measuring the day-time intensity. 2/
- 7.3. Where a rear position (side) lamp is reciprocally incorporated with a dual-intensity stop-lamp and is designed to operate permanently with an additional system to regulate the intensity of the light emitted, measurement of the light emitted shall be performed with the same voltage applied to the system as would, if applied to the filament lamp, enable the lamp to produce the prescribed normal luminous flux.

2/ The functioning and installation conditions of these additional systems will be defined by special provisions.

- 7.3.1. Where a position (side) lamp is reciprocally incorporated with another lamp, and is designed to operate permanently with an additional system to regulate the intensity of the light emitted, measurement of the light emitted shall be performed at 6,75 V, 13.5 V or 28 V respectively, where the additional system is part of the device.
- 7.3.2. Where the additional system is not part of the device, then the tests shall be performed at the rated secondary design voltage applied to the light source. The test laboratory may require from the manufacturer the additional system needed to regulate the light source.
- 7.4. The limits of the apparent surface in the direction of the reference axis of a light-signalling device shall be determined.
- 7.5. In the case of a category S3 stop lamp, which is intended to be mounted inside the vehicle, a sample plate or sample plates (in case of different possibilities) as supplied (see paragraph 2.2.5.) shall be positioned in front of the lamp to be tested, in the geometrical position(s) as described in the application drawing(s) (see paragraph 2.2.1.).

8. COLOUR OF LIGHT EMITTED

The colour of the light emitted inside the field of the light distribution grid defined in paragraph 2 of Annex 4 shall be within the limits of the coordinates prescribed in Annex 5 to this Regulation. Outside this field, no sharp variation of colour shall be observed.

9. CONFORMITY OF PRODUCTION

The Conformity of Production procedures shall comply with those set out in the Agreement, Appendix 2 (E/ECE/324-E/ECE/TRANS/505/Rev.2), with the following requirements:

- 9.1. Lamps approved under this Regulation shall be so manufactured as to conform to the type approved by meeting the requirements set forth in paragraphs 6 and 8 above.
- 9.2. The minimum requirements for Conformity of Production control procedures set forth in Annex 6 to this Regulation shall be complied with.
- 9.3. The minimum requirements for sampling by an inspector set forth in Annex 7 to this Regulation shall be complied with.

9.4. The authority which has granted type approval may at any time verify the conformity control methods applied in each production facility. The normal frequency of these verifications shall be once every two years.

10. PENALTIES FOR NON-CONFORMITY OF PRODUCTION

10.1. The approval granted in respect of a device may be withdrawn if the foregoing conditions are not satisfied.

10.2. If a Contracting Party to the Agreement applying this Regulation withdraws an approval it has previously granted, it shall forthwith so notify the other Contracting Parties applying this Regulation by means of a communication form conforming to the model in Annex 2 to this Regulation.

11. PRODUCTION DEFINITELY DISCONTINUED

If the holder of the approval completely ceases to manufacture a device, approved in accordance with this Regulation, he shall so inform the authority which granted the approval. Upon receiving the relevant communication, that authority shall inform thereof the other Parties to the 1958 Agreement applying this Regulation, by means of a copy of a communication form conforming to the model in Annex 2 to this Regulation.

12. REMARKS CONCERNING COLOURS AND PARTICULAR DEVICES

The Parties to the Agreement to which this Regulation is annexed are not precluded by article 3 of that Agreement from prohibiting, for devices installed on vehicles registered by them, certain colours for which provision is made in this Regulation, or from prohibiting for all categories or for certain categories of vehicles registered by them stop-lamps having only one level of luminous intensity.

13. NAMES AND ADDRESSES OF TECHNICAL SERVICES RESPONSIBLE FOR CONDUCTING APPROVAL TESTS, AND OF ADMINISTRATIVE DEPARTMENTS

The Parties to the 1958 Agreement applying this Regulation shall communicate to the United Nations Secretariat the names and addresses of the Technical Services responsible for conducting approval tests and of the Administrative Departments which grant approval and to which forms certifying approval or extension or refusal or withdrawal of approval or production definitely discontinued, issued in other countries, are to be sent.

14. TRANSITIONAL PROVISIONS

- 14.1. Signalling lamps not equipped with filament lamps and category S3 stop lamps intended to be mounted inside a vehicle.
- 14.1.1. As from the date of entry into force of Supplement 6 to the 02 series of amendments, no Contracting Party applying this Regulation shall refuse to grant approvals under this Regulation as amended by Supplement 6 to the 02 series of amendments.
- 14.1.2. As from 36 months after the date of entry into force of Supplement 6 to the 02 series of amendments, Contracting Parties applying this Regulation shall grant approvals only if the type of lamps as described in paragraph 14.1. above meets the requirements of this Regulation as amended by Supplement 6 to the 02 series of amendments.
- 14.1.3. Contracting Parties applying this Regulation shall not refuse to grant extensions of approvals to the preceding series of amendments to this Regulation.
- 14.1.4. Contracting Parties applying this Regulation shall continue to grant approvals to those types of lamps as described in paragraph 14.1. above which comply with the requirements of this Regulation as amended by the preceding series of amendments during the 36 months' period which follows the date of entry into force of Supplement 6 to the 02 series of amendments.
- 14.2. Fitting of lamps described in paragraph 14.1. above on a vehicle.
- 14.2.1. As from the date of entry into force of Supplement 6 to the 02 series of amendments, no Contracting Party applying this Regulation shall prohibit the fitting on a vehicle of lamps described in paragraph 14.1. above approved under this Regulation as amended by Supplement 6 to the 02 series of amendments.
- 14.2.2. Contracting Parties applying this Regulation shall continue to allow the fitting on a vehicle of lamps described in paragraph 14.1. above approved to this Regulation as amended by the preceding series of amendments during the 48 months' period which follows the date of entry into force of Supplement 6 to the 02 series of amendments.
- 14.2.3. Upon the expiration of a period of 48 months after the date of entry into force of Supplement 6 to the 02 series of amendments, Contracting Parties applying this Regulation may prohibit the fitting of lamps described in paragraph 14.1. above which do not meet the requirements of this Regulation as amended by Supplement 6 to the 02 series of amendments on a new vehicle for which type approval or individual approval was granted more than 24 months after the entry into force of Supplement 6 to the 02 series of amendments to this Regulation.

- 14.2.4. Upon expiration of a period of 60 months after the date of entry into force of Supplement 6 to the 02 series of amendments, Contracting Parties applying this Regulation may prohibit the fitting of lamps as described in paragraph 14.1. above which do not meet the requirements of this Regulation as amended by Supplement 6 to the 02 series of amendments on a new vehicle first registered more than 60 months after the date of entry into force of Supplement 6 to the 02 series of amendments to this Regulation.

Annex 1

FRONT AND REAR POSITION (SIDE) LAMPS, END-OUTLINE MARKER LAMPS AND
 STOP-LAMPS: MINIMUM ANGLES REQUIRED FOR LIGHT DISTRIBUTION
 IN SPACE OF THESE LAMPS 1/

In all cases, the minimum vertical angles of light distribution in space are 15° above and 15° below the horizontal for all categories of devices included in this Regulation, except:

- (a) for lamps with a permissible mounting height # 750 mm above the ground, for which they are 15° above and 5° below the horizontal;
- (b) for category S3 stop lamp for which they are 10° above and 5° below the horizontal;

Minimum horizontal angles of light distribution in space

Front position (side) lamps,
 end-outline marker lamps

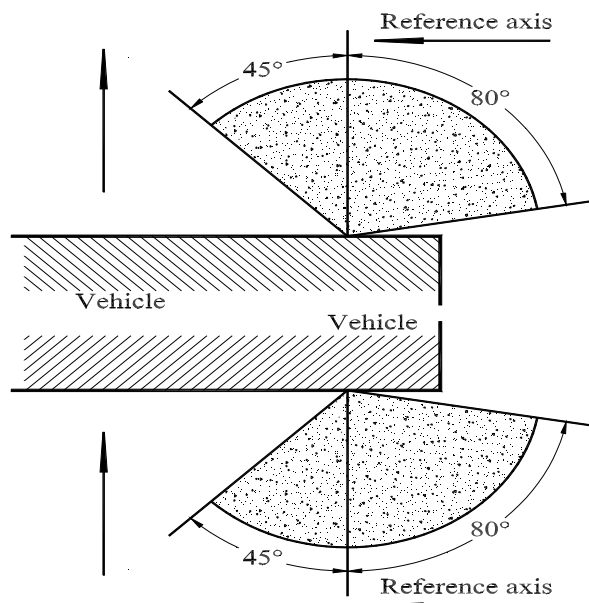

Rear position lamps,
 end-outline marker lamps

1/ The angles shown in these diagrams are correct for devices to be mounted on the right side of the vehicle. The arrows point to the front of the vehicle.

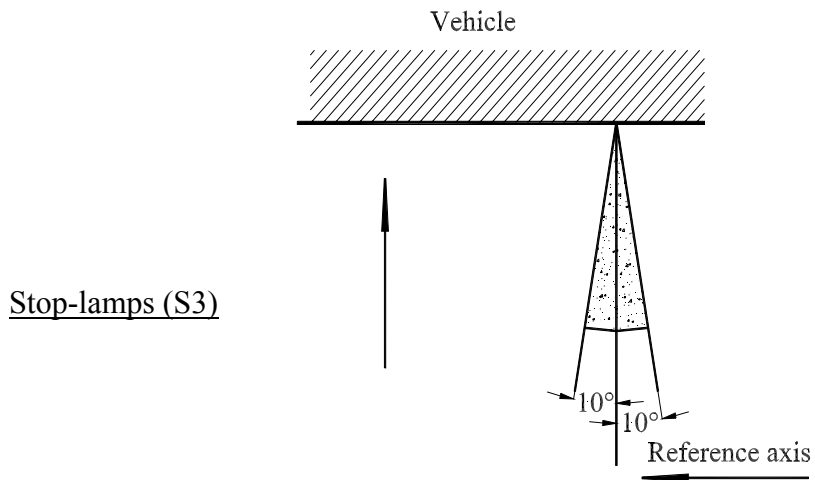
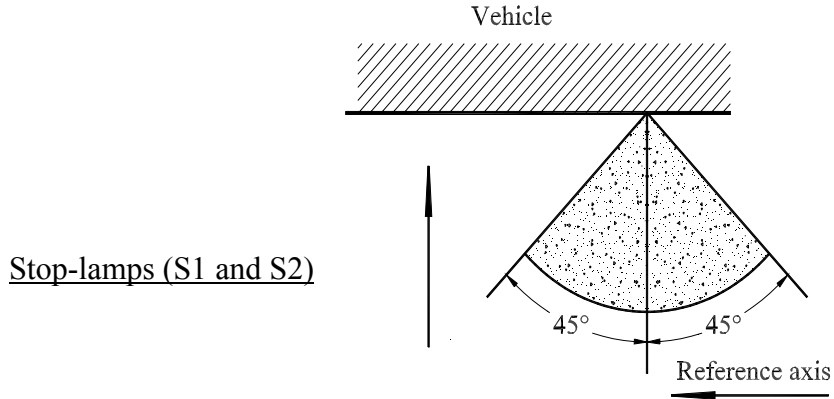

Annex 2

COMMUNICATION

(Maximum format: A4 (210 x 297 mm))

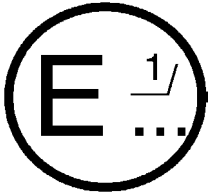

issued by :

Name of administration:

.....
.....
.....

concerning: 2/

- APPROVAL GRANTED
- APPROVAL EXTENDED
- APPROVAL REFUSED
- APPROVAL WITHDRAWN
- PRODUCTION DEFINITELY DISCONTINUED

of a type of device pursuant to Regulation No. 7

Approval No.

Extension No.

1. Trade name or mark of the device:.....
2. Manufacturer's name for the type of device:.....
3. Manufacturer's name and address:
4. If applicable, name and address of the manufacturer's representative:
-
5. Submitted for approval on:.....
6. Technical service responsible for conducting approval tests:
7. Date of report issued by that service:
8. Number of report issued by that service:.....

9. Concise description: 3/
By category of lamp:
For mounting either outside or inside or both 2/
Colour of light emitted: red / white 2/
Number and category of filament lamp(s):
10. Position of the approval mark:.....
11. Reason(s) for extension (if applicable):.....
.....
12. Approval granted/extended/refused/withdrawn: 2/
13. Place:
14. Date:
15. Signature:.....
16. The list of documents deposited with the Administrative Service, which has granted approval, is annexed to this communication and may be obtained on request.

1/ Distinguishing number of the country which has granted/extended/refused/withdrawn approval (see approval provisions in the Regulation).

2/ Strike out what does not apply.

3/ For lamps with non-replaceable light sources indicate the number and the total wattage of the light sources.

Annex 3

EXAMPLES OF ARRANGEMENTS OF THE APPROVAL MARKS

1. Front position (side) lamp

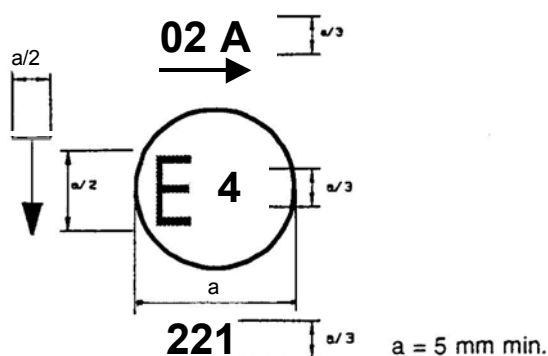

The device bearing the approval mark shown above is a front position (side) lamp approved in the Netherlands (E4), under approval number 221 pursuant to Regulation No. 7.

The number mentioned close to the symbol "A" indicates that approval was granted in accordance with the requirements of Regulation No. 7 as amended by the 02 series of amendments. The horizontal arrow indicates the side on which the required photometric specifications are met up to an angle of 80° H. The vertical arrow starting from a horizontal segment and directed downwards indicates a permissible mounting height of equal to or less than 750 mm from the ground for this device.

2. Rear position (side) lamp



The device bearing the approval mark shown above is a rear position (side) lamp approved in the Netherlands (E4) under approval number 221 pursuant to Regulation No. 7, which may also be used in an assembly of two rear position (side) lamps.

The number mentioned below the symbol "RD" indicates that approval was granted in conformity with the requirements of Regulation No. 7 as amended by the 02 series of amendments.

The absence of an arrow means that, both right and left, the required photometric specifications are met up to an angle of 80° H.

3. Stop-lamp



The device bearing the approval mark shown above is a stop-lamp with one level of illumination approved in the Netherlands (E4) under approval number 221 pursuant to Regulation No. 7.

The number mentioned below the symbol "S1" indicates that the approval was granted in conformity with the requirements of Regulation No. 7 as amended by the 02 series of amendments.

4. Device comprising both a rear position (side) lamp and a stop-lamp

RD - S2 D
02



221

The device bearing the approval mark shown above is a device comprising both a rear position (side) lamp and a stop-lamp with two levels of illumination, approved in the Netherlands (E4) under approval number 221 pursuant to Regulation No. 7.

The number mentioned below the symbol "RD-S2D" indicates that approval was granted in conformity with the requirements of Regulation No. 7 as amended by the 02 series of amendments. The rear position (side) lamp is incorporated into a stop-lamp with two levels of illumination, which may also be used in an assembly of two lamps.

The absence of an arrow means that, both right and left, the required photometric specifications are met up to an angle of 80° H.

Note: The approval number and the additional symbols shall be placed close to the circle and either above or below the letter "E" or to the right or to the left of that letter. The digits of the approval number shall be on the same side of the letter "E" and face the same direction. The approval number and the additional symbol including the number of the series of amendments to the Regulation in question, where applicable, shall be placed diametrically opposite to each other.

The use of Roman numerals as approval numbers should be avoided so as to prevent any confusion with other symbols.

5. Marking of independent lamps

F 2a AR R S1
00 01 00 02 02
E9
1432

The above example corresponds to the marking of a lens intended to be used in different types of lamps. The approval marks indicate that the device was approved in Spain (E9) under approval number 1432 and comprises:

A rear fog lamp (F) approved in accordance with Regulation No. 38 in its original version,

A rear direction indicator lamp of category 2a approved in accordance with the 01 series of amendments to Regulation No. 6,

A reversing lamp (AR) approved in accordance with Regulation No. 23 in its original version,

A red rear position (side) lamp (R) approved in accordance with the 02 series of amendments to Regulation No. 7,

A stop-lamp with one level of illumination (S1) approved in accordance with the 02 series of amendments to Regulation No. 7.

6. Simplified marking of grouped, combined or reciprocally incorporated lamps when two or more lamps are part of the same assembly

(The vertical and horizontal lines schematize the shape of the light-signalling device. These are not part of the approval mark)

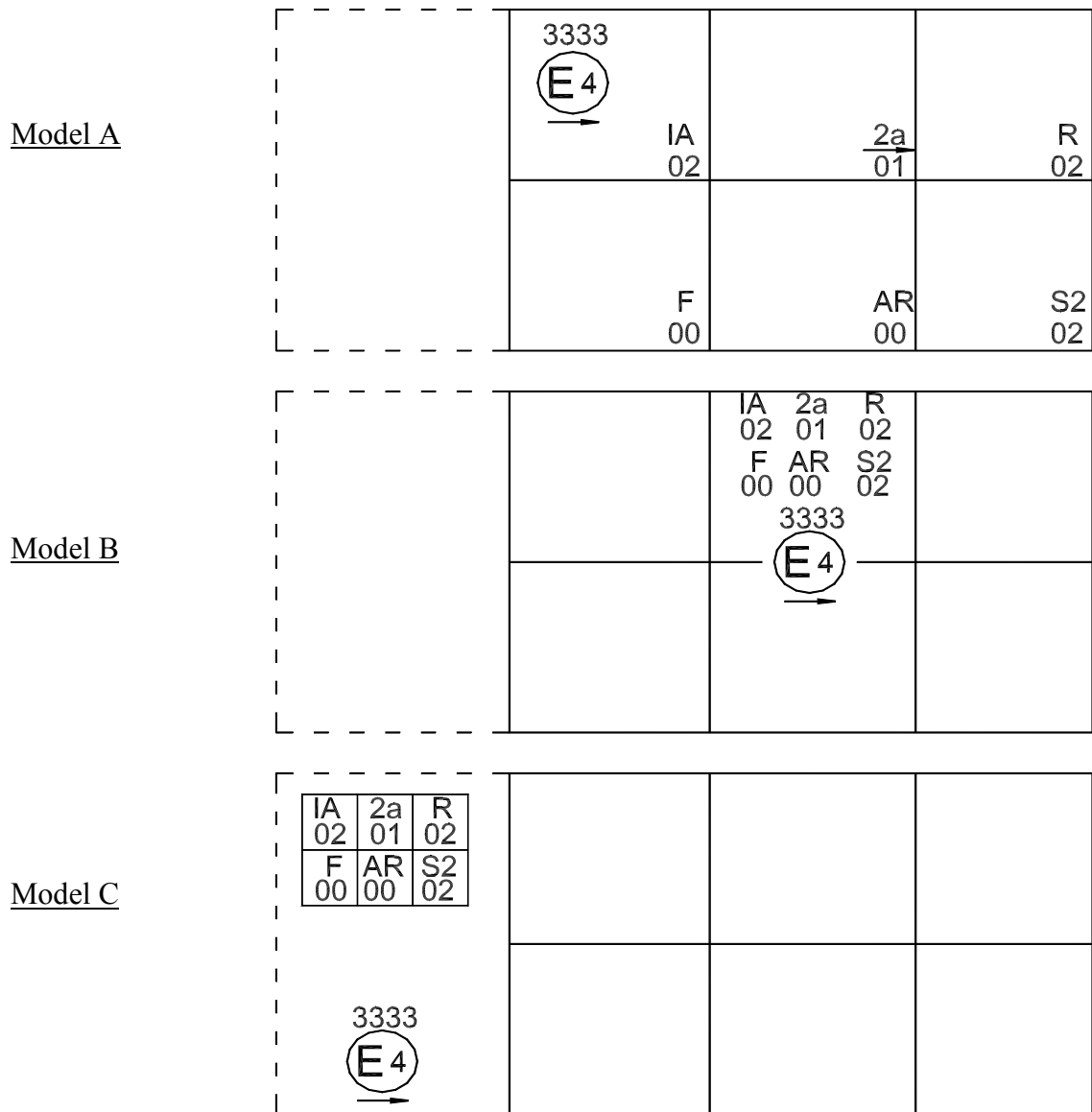

Note: These three examples of approval marks (models A, B and C) represent three possible variables for the marking of a lighting device when two or more lamps are part of the same assembly of grouped, combined or reciprocally incorporated lamps.

They indicate that the device was approved in the Netherlands (E4) under approval number 3333 and comprises:

A reflex-reflector of class 1A approved in accordance with the 02 series of amendments to Regulation No. 3,

A rear direction indicator lamp of category 2a approved in accordance with the 01 series of amendments to Regulation No. 6,

A red rear position (side) lamp (R) approved in accordance with the 02 series of amendments to Regulation No. 7,

A rear fog lamp (F) approved in accordance with Regulation No. 38 in its original version,

A reversing lamp (AR) approved in accordance with Regulation No. 23 in its original version,

A stop-lamp with two levels of illumination (S2) approved in accordance with the 02 series of amendments to Regulation No. 7.

Note: The three examples of approval marks (models D, E and F) below correspond to a lighting device bearing an approval mark comprising:

A front position (side) lamp approved in accordance with the 02 series of amendments to Regulation No. 7,

A headlamp with a passing beam designed for right- and left-hand traffic and a driving beam with a maximum intensity comprised between 86,250 and 111,250 candelas (indicated by the number "30"), approved in accordance with the 02 series of amendments to Regulation No. 20,

A front fog lamp approved in accordance with the 02 series of amendments to Regulation No. 19,

A front direction indicator lamp of category 1a approved in accordance with the 01 series of amendments to Regulation No. 6.

Model D

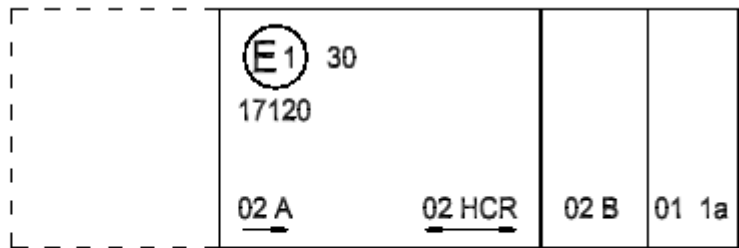

Model E

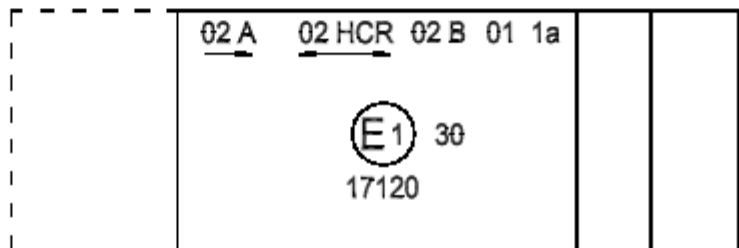

Model F

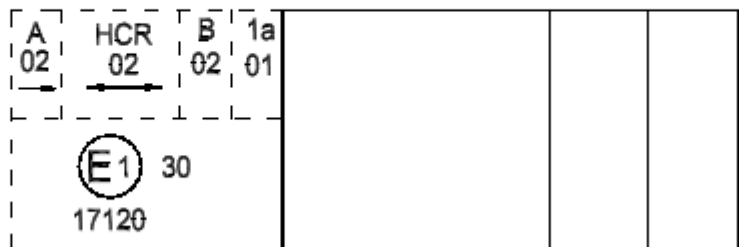

7. Lamp reciprocally incorporated with a headlamp

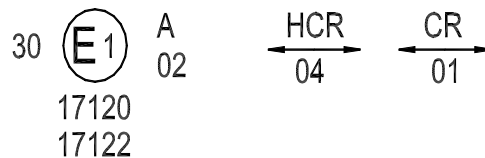

The above example corresponds to the marking of a lens intended to be used in different types of headlamps, namely:

Either A headlamp with a passing beam designed for right- and left-hand traffic and a driving beam with a maximum intensity comprised between 86,250 and 111,250 candelas (indicated by the number "30") approved in Germany (E1) in accordance with the requirements of Regulation No. 8 as amended by the 04 series of amendments, which is reciprocally incorporated with

A front position (side) lamp approved in accordance with the 02 series of amendments to Regulation No. 7;

Or A headlamp with a passing beam designed for right- and left-hand traffic and a driving beam, approved in Germany (E1) in accordance with the requirements of Regulation No. 1 as amended by the 01 series of amendments, which is reciprocally incorporated with

The same front position (side) lamp as above;

Or even either of the above-mentioned headlamps approved as a single lamp.

The main body of the headlamp shall bear the only valid approval number, for instance:

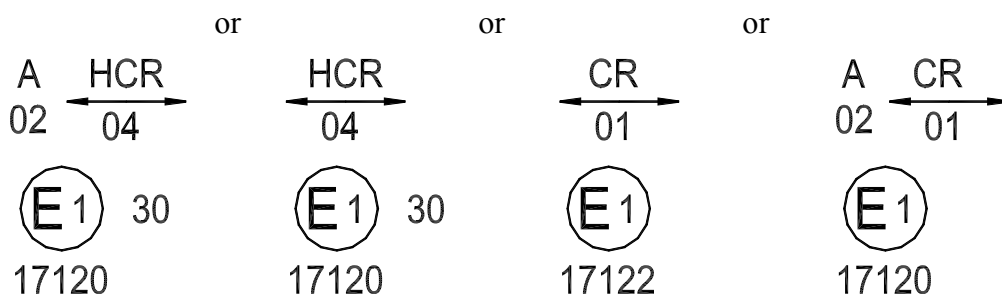

8. Light source modules

MD E3 17325

The light source module bearing the identification code shown above has been approved together with a lamp approved in Italy (E3) under approval number 17325.

Annex 4

PHOTOMETRIC MEASUREMENTS

1. Measurement methods
- 1.1. During photometric measurements, stray reflections shall be avoided by appropriate masking.
- 1.2. In case the results of measurements should be challenged, measurements shall be carried out in such a way as to meet the following requirements:
 - 1.2.1. The distance of measurement shall be such that the law of the inverse of the square of the distance is applicable;
 - 1.2.2. The measuring equipment shall be such that the angular aperture of the receiver viewed from the reference centre of the lamp is comprised between 10 angular minutes and one degree;
 - 1.2.3. The intensity requirement for a particular direction of observation shall be deemed to be satisfied if that requirement is met in a direction deviating by not more than one-quarter of a degree from the direction of observation.
- 1.3. In the case where the device may be installed on the vehicle in more than one or in a field of different positions the photometric measurements shall be repeated for each position or for the extreme positions of the field of the reference axis specified by the manufacturer.

2. Table of standard light distribution

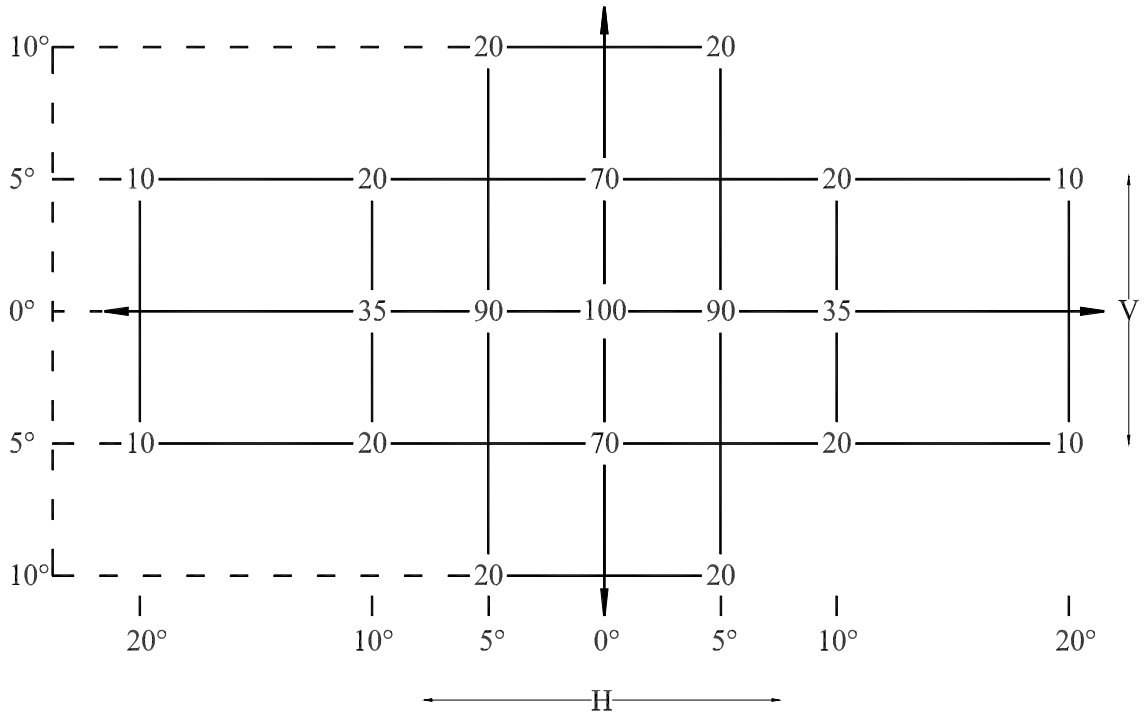

Table of light distribution for category S3 stop-lamp

10°	32	-	64	-	32
5°	64	100	100	100	64
0°	64	100	100	100	64
5°	64	100	100	100	64
	10°	5°	0°	5°	10°

- 2.1. The direction $H = 0^\circ$ and $V = 0^\circ$ corresponds to the reference axis. (On the vehicle it is horizontal, parallel to the median longitudinal plane of the vehicle and oriented in the required direction of visibility.) It passes through the centre of reference. The values shown in the table give, for the various directions of measurement, the minimum intensities as a percentage of the minimum required in the axis for each lamp (in the direction $H = 0^\circ$ and $V = 0^\circ$).
- 2.2. Within the field of light distribution of paragraph 2., schematically shown as a grid, the light pattern should be substantially uniform, i.e. the light intensity in each direction of a part of the field formed by the grid lines shall meet at least the lowest minimum value being shown on the grid lines surrounding the questioned direction as a percentage.
- 2.3. However, in the case where a device is intended to be installed at a mounting height of equal to or less than 750 mm above the ground, the photometric intensity is verified only up to an angle of 5° downwards.

3. Photometric measurement of lamps

The photometric performance shall be checked:

- 3.1. For non-replaceable light sources (filament lamps and other):

with the light sources present in the lamp, in accordance with paragraph 7.1.1. of this Regulation.
- 3.2. For replaceable filament lamps:
when equipped with filament lamps at 6.75 V, 13.5 V or 28.0 V, the luminous intensity values produced shall be corrected. The correction factor is the ratio between the reference luminous flux and the mean value of the luminous flux found at the voltage applied (6.75 V, 13.5 V or 28.0 V). The actual luminous fluxes of each filament lamp used shall not deviate more than $\nabla 5$ per cent from the mean value. Alternatively a standard filament lamp may be used in turn, in each of the individual positions, operated at its reference flux, the individual measurements in each position being added together.
- 3.3. For any signalling lamp except those equipped with filament lamp(s), the luminous intensities, measured after one minute and after 30 minutes of operation, shall comply with the minimum and maximum requirements. The luminous intensity distribution after one minute of operation can be calculated from the luminous intensity distribution after 30 minutes of operation by applying at each test point the ratio of luminous intensities measured at HV after one minute and after 30 minutes of operation.

Annex 5

COLOURS OF LIGHTS

TRICHROMATIC COORDINATES

RED:	Limit towards yellow:	$y \leq 0.335$
	Limit towards purple:	$y \geq 0.980 - x$
WHITE:	Limit towards blue	: $x \geq 0.310$
	Limit towards yellow	: $x \leq 0.500$
	Limit towards green	: $y \leq 0.150 + 0.640x$
	Limit towards green	: $y \leq 0.440$
	Limit towards purple	: $y \geq 0.050 + 0.750x$
	Limit towards red	: $y \geq 0.382$

For checking these colorimetric characteristics, a source of light at a colour temperature of 2,856 K corresponding to illuminant A of the International Commission on Illumination (CIE) shall be used. However, for lamps equipped with non-replaceable light sources (filament lamps and other), the colorimetric characteristics should be verified with the light sources present in the lamp, in accordance with paragraph 7.1.1. of this Regulation.

In the case of a category S3 stop lamp, which is intended to be mounted inside the vehicle, the colorimetric characteristics shall be verified with the worst case combination(s) of lamp and rear window(s) or sample plate(s).

Annex 6

MINIMUM REQUIREMENTS FOR CONFORMITY OF PRODUCTION CONTROL PROCEDURES

1. GENERAL

- 1.1. The conformity requirements shall be considered satisfied from a mechanical and geometric standpoint, if the differences do not exceed inevitable manufacturing deviations within the requirements of this Regulation.
- 1.2. With respect to photometric performances, the conformity of mass-produced lamps shall not be contested if, when testing photometric performances of any lamp chosen at random and equipped with a standard filament lamp, or when the lamps are equipped with non-replaceable light sources (filament lamps or other), and when all measurements are made at 6.75 V, 13.5 V or 28.0 V respectively:
 - 1.2.1. no measured value deviates unfavourably by more than 20 per cent from the values prescribed in this Regulation.
 - 1.2.2. If, in the case of a lamp equipped with a replaceable light source and if results of the test described above do not meet the requirements, tests on lamps shall be repeated using another standard filament lamp.
- 1.3. The chromaticity coordinates shall be complied with when the lamp is equipped with a standard filament lamp, or for lamps equipped with non-replaceable light sources (filament lamps or other), when the colorimetric characteristics are verified with the light source present in the lamp.

2. MINIMUM REQUIREMENTS FOR VERIFICATION OF CONFORMITY BY THE MANUFACTURER

For each type of lamp the holder of the approval mark shall carry out at least the following tests, at appropriate intervals. The tests shall be carried out in accordance with the provisions of this Regulation.

If any sampling shows non-conformity with regard to the type of test concerned, further samples shall be taken and tested. The manufacturer shall take steps to ensure the conformity of the production concerned.

2.1. Nature of tests

Tests of conformity in this Regulation shall cover the photometric and colorimetric characteristics.

2.2. Methods used in tests

2.2.1. Tests shall generally be carried out in accordance with the methods set out in this Regulation.

2.2.2. In any test of conformity carried out by the manufacturer, equivalent methods may be used with the consent of the competent authority responsible for approval tests. The manufacturer is responsible for proving that the applied methods are equivalent to those laid down in this Regulation.

2.2.3. The application of paragraphs 2.2.1. and 2.2.2. requires regular calibration of test apparatus and its correlation with measurements made by a Competent Authority.

2.2.4. In all cases the reference methods shall be those of this Regulation, particularly for the purpose of administrative verification and sampling.

2.3. Nature of sampling

Samples of lamps shall be selected at random from the production of a uniform batch. A uniform batch means a set of lamps of the same type, defined according to the production methods of the manufacturer.

The assessment shall in general cover series production from individual factories. However, a manufacturer may group together records concerning the same type from several factories, provided these operate under the same quality system and quality management.

2.4. Measured and recorded photometric characteristics

The sampled lamp shall be subjected to photometric measurements for the minimum values at the points listed in Annex 4 and the chromaticity coordinates listed in Annex 5, provided for in the Regulation.

2.5. Criteria governing acceptability

The manufacturer is responsible for carrying out a statistical study of the test results and for defining, in agreement with the Competent Authority, criteria governing the acceptability of his products in order to meet the specifications laid down for verification of conformity of products in paragraph 9.1. of this Regulation.

The criteria governing the acceptability shall be such that, with a confidence level of 95 per cent, the minimum probability of passing a spot check in accordance with Annex 7 (first sampling) would be 0.95.

Annex 7

MINIMUM REQUIREMENTS FOR SAMPLING BY AN INSPECTOR

1. GENERAL

- 1.1. The conformity requirements shall be considered satisfied from a mechanical and a geometric standpoint, in accordance with the requirements of this Regulation, if any, if the differences do not exceed inevitable manufacturing deviations.
- 1.2. With respect to photometric performance, the conformity of mass-produced lamps shall not be contested if, when testing photometric performances of any lamp chosen at random and equipped with a standard filament lamp, or when the lamps are equipped with non-replaceable light sources (filament lamps or other), and when all measurements are made at 6.75 V, 13.5 V or 28.0 V respectively:
- 1.2.1. no measured value deviates unfavourably by more than 20 per cent from the values prescribed in this Regulation.
- 1.2.2. If, in the case of a lamp equipped with a replaceable light source and if results of the test described above do not meet the requirements, tests on lamps shall be repeated using another standard filament lamp.
- 1.2.3. Lamps with apparent defects are disregarded.
- 1.3. The chromaticity coordinates shall be complied with when the lamp is equipped with a standard filament lamp, or for lamps equipped with non-replaceable light sources (filament lamps or other), when the colorimetric characteristics are verified with the light source present in the lamp.

2. FIRST SAMPLING

In the first sampling four lamps are selected at random. The first sample of two is marked A, the second sample of two is marked B.

2.1. The conformity is not contested

- 2.1.1. Following the sampling procedure shown in Figure 1 of this annex the conformity of mass-produced lamps shall not be contested if the deviation of the measured values of the lamps in the unfavourable directions are:

2.1.1.1. sample A

A1: one lamp 0 per cent
one lamp not more than 20 per cent

A2: both lamps more than 0 per cent
but not more than 20 per cent
go to sample B

2.1.1.2. sample B

B1: both lamps 0 per cent

2.1.2. or, if the conditions of paragraph 1.2.2. for sample A are fulfilled.

2.2. The conformity is contested

2.2.1. Following the sampling procedure shown in Figure 1 of this annex the conformity of mass-produced lamps shall be contested and the manufacturer requested to make his production meet the requirements (alignment) if the deviations of the measured values of the lamps are:

2.2.1.1. sample A

A3: one lamp not more than 20 per cent
one lamp more than 20 per cent
but not more than 30 per cent

2.2.1.2. sample B

B2: in the case of A2
one lamp more than 0 per cent
but not more than 20 per cent
one lamp not more than 20 per cent

B3: in the case of A2
one lamp 0 per cent
one lamp more than 20 per cent
but not more than 30 per cent

2.2.2. or, if the conditions of paragraph 1.2.2. for sample A are not fulfilled.

2.3. Approval withdrawn

Conformity shall be contested and paragraph 10 applied if, following the sampling procedure in Figure 1 of this annex, the deviations of the measured values of the lamps are:

2.3.1. sample A

A4:	one lamp not more than	20 per cent
	one lamp more than	30 per cent
A5:	both lamps more than	20 per cent

2.3.2. sample B

B4:	in the case of A2	
	one lamp more than	0 per cent
	but not more than	20 per cent
	one lamp more than	20 per cent
B5:	in the case of A2	
	both lamps more than	20 per cent
B6:	in the case of A2	
	one lamp	0 per cent
	one lamp more than	30 per cent

2.3.3. or, if the conditions of paragraph 1.2.2. for samples A and B are not fulfilled.

3. REPEATED SAMPLING

In the cases of A3, B2, B3 a repeated sampling, third sample C of two lamps and fourth sample D of two lamps, selected from stock manufactured after alignment, is necessary within two months' time after the notification.

3.1. The conformity is not contested

3.1.1. Following the sampling procedure shown in Figure 1 of this annex the conformity of mass-produced lamps shall not be contested if the deviations of the measured values of the lamps are:

3.1.1.1. sample C

C1:	one lamp	0 per cent
	one lamp not more than	20 per cent

C2:	both lamps more than	0 per cent
	but not more than	20 per cent
	go to sample D	

3.1.1.2. sample D

D1:	in the case of C2	
	both lamps	0 per cent

3.1.2. or, if the conditions of paragraph 1.2.2. for sample C are fulfilled.

3.2. The conformity is contested

3.2.1. Following the sampling procedure shown in Figure 1 of this annex the conformity of mass-produced lamps shall be contested and the manufacturer requested to make his production meet the requirements (alignment) if the deviations of the measured values of the lamps are:

3.2.1.1. sample D

D2:	in the case of C2	
	one lamp more than	0 per cent
	but not more than	20 per cent
	one lamp not more than	20 per cent

3.2.1.2. or, if the conditions of paragraph 1.2.2. for sample C are not fulfilled.

3.3. Approval withdrawn

Conformity shall be contested and paragraph 10 applied if, following the sampling procedure in Figure 1 of this annex, the deviations of the measured values of the lamps are:

3.3.1. sample C

C3:	one lamp not more than	20 per cent
	one lamp more than	20 per cent
C4:	both lamps more than	20 per cent

3.3.2. sample D

D3:	in the case of C2	
	one lamp 0 or more than	0 per cent
	one lamp more than	20 per cent

3.3.3. or, if the conditions of paragraph 1.2.2. for samples C and D are not fulfilled.

Figure 1

